



Ishida OMNi-4000

Fully Automatic Wrapper/Integrated Printer/Color Touchscreen

From ergonomic design to high-speed performance, the OMNi-4000 offers the latest technology to streamline backroom prepackaging operations. This fully automatic system weighs, wraps and labels at an industry-leading speed of up to 30 packages per minute. Eye-catching labels containing country of origin information and safe handling instructions print at 100 mm per second. With the ability to handle family pack trays up to 16 inch wide, the OMNi-4000 excels in heavy production backrooms. This versatile wrapper also saves film by automatically switching between two film sizes that accommodate a wide range of tray sizes.

Designed to enhance production, the OMNi-4000's large color touchscreen allows operators to easily access PLU and tray lists. Category keys further simplify PLU lookup. Front film loading minimizes production interruptions.

The wrapper's space-saving design features a small footprint, allowing flexible integration into backroom operations. What's more, the OMNi-4000 networks with ScaleLink Pro and other third-party scale management software via standard Ethernet or optional internal wireless communication for consistent and accurate pricing.

Specifications

Capacity:

15 lb x 0.005 lb / 30 lb x 0.01 lb
(dual-range standard)
12 lb wrapping capacity

Display:

10.4 in color touchscreen

Power Supply:

208V, 220V, 240V (3 phase), standard
20 A circuit

Power Consumption:

1000W (standby), 1400W (maximum)

Wrapping Size:

Width: 5.1 in - 16.1 in (130 mm - 410 mm)
Length: 5.1 in - 10.2 in (130 mm - 260 mm)
Height: 0.8 in - 5.1 in (20 mm - 130 mm)

Print Items:

Item name, unit price, weight, total price,
special message, bar code, ingredients,
tare, pack time

Cycle Speed:

Weigh/wrap/label: up to 30 packs/minute
Wrap only: up to 30 packs/minute
Label only: 35 or more packs/minute

Film:

Two rolls, automatic film selection
Roll sizes:
14 in to 24 in (350 mm to 600 mm)

Label Size:

3.2 in (80 mm) maximum width
4.7 in (120 mm) maximum length
3.4 in (85 mm) maximum length for
automatic application
2.3 in (60 mm) maximum length for left
side label application

Label Roll:

9.0 in (230 mm) maximum
3.0 in (77 mm) minimum

Humidity Range:

30-80%

Recommended Temperature:

50°F to 86°F (10°C to 30°C)

Classification:

NTEP CC 06-029
ETL listed

Warranty:

One-year limited warranty

Standard Features

- Large color touchscreen
- Weigh/wrap/label up to 30 packs/minute
- Handles family-pack trays up to 16 inch wide
- Static TCP/IP Ethernet communication
- Automatic film selection and robotic label application
- Front loading film
- Stores and prints graphics for custom labeling,
- Safe handling instructions, country of origin, and more
- Large 9 inch label roll
- Dual-range weighing (0-15 lb x 0.005 lb/15-30 lb x 0.01 lb)
- Compatible with third-party communication software, including Invatron's PLUM and ADC's InterScale
- 3 inch thermal head
- Adjustable touchscreen viewing angle
- 19 tactile keys
- 34 MB memory

OMNi-4000

PART #	MODEL	CAPACITY
88940	OMNi-4000, fully automatic wrapper/integrated printer/color touchscreen	15 lb x 0.005 lb/30 lb x 0.01 lb

Please refer to the Labels section of this catalog for ordering information and case quantity pricing.

Ishida OMNi-4000

Fully Automatic Wrapper/Integrated Printer/Color Touchscreen

DIMENSIONS			
A	68.7 in - 70.7 in	F	35.0 in
B	49.4 in - 51.4 in	G	52.0 in
C	43.3 in - 45.3 in	H	43.4 in
D	49.6 in	I	46.2 in
E	33.7 in - 35.7 in		

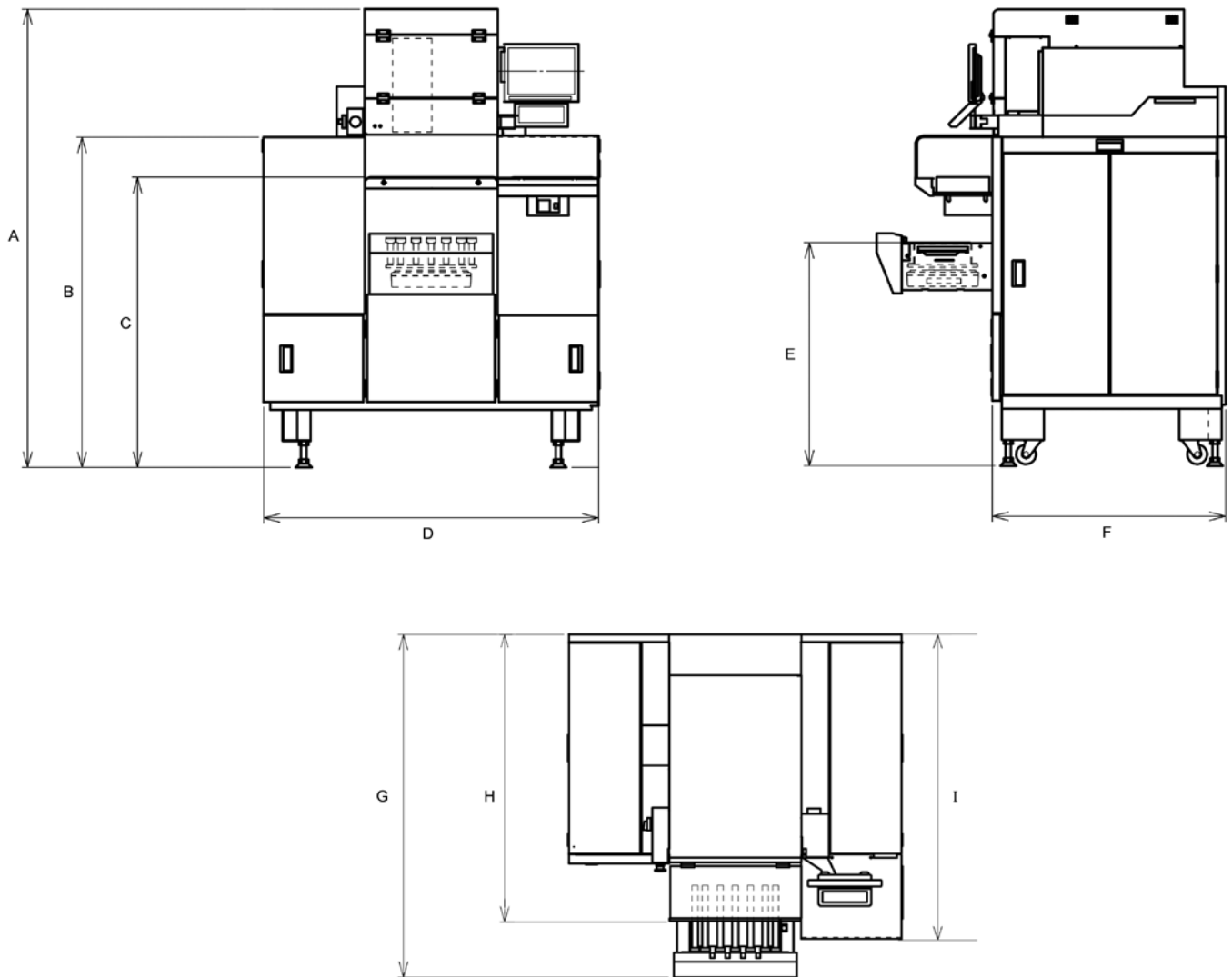

Ishida OMNi-4000

Accessory configurations
Drawings not to scale

5 ft Table

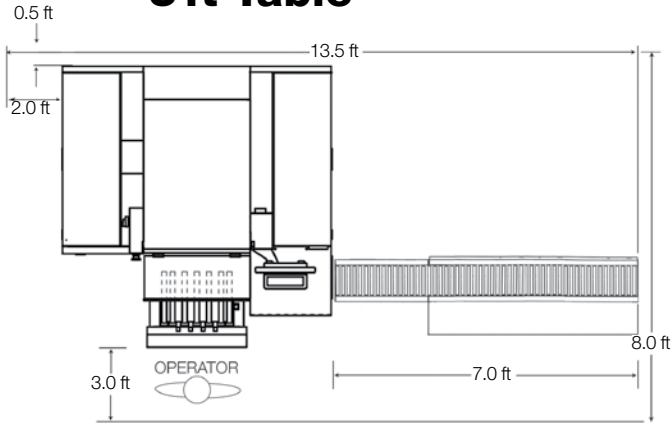

3 ft Table

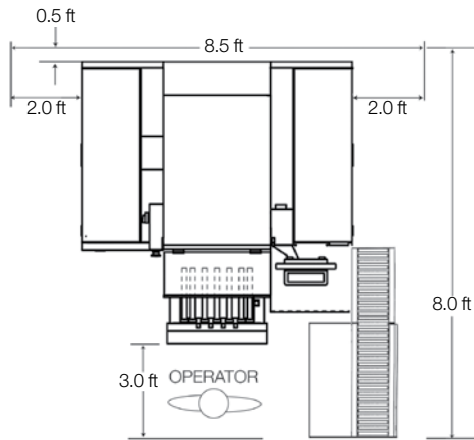
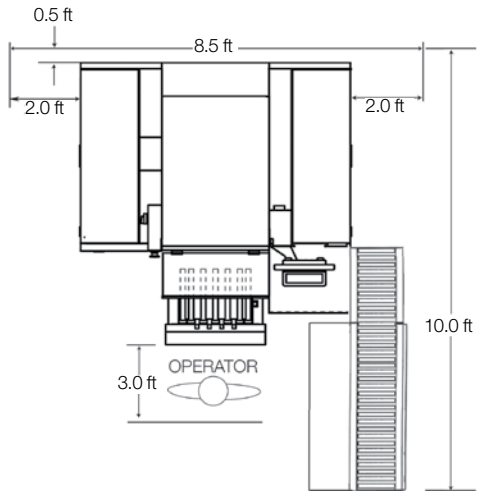
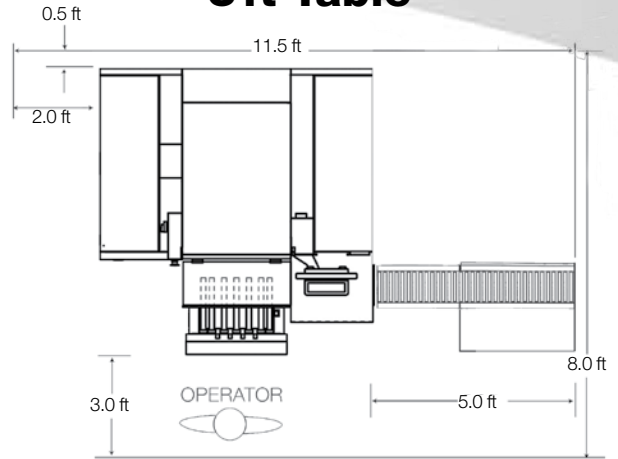

Rotary Bin

